

STANDARD PRESSURE GAUGES ACCORDING TO DIN EN 837-1



DRUCK & TEMPERATUR

Nominal diameter 40, 50, 63

Connection brass

Connection position bottom or centric back



For normal demands in accuracy of indication and construction.

This devices can be used in all applications where liquid or gaseous media are not highly viscous and do not attack copper alloys or crystallize.

Type	4101	4151	4201	4251	4301	4351	Options
Nominal diameter	40		50		63		
Symbol							NS 63 im ABS case, cl.1,6 0...4 bar with green field and red mark G1/4 or G3/8
Accuracy DIN EN 837-1	Class 2,5				Class 1,6		
Measuring ranges	0...0,6 bar up to 0...400 bar, positive and negative overpressure						
Applications	Constant load: 3/4 x end of scale value Alternating load: 2/3 x end of scale value						
Case	Steel, black						
Ring	Slip ring, pressed				Slip ring, screwed		
Measurement	Cu - alloy						Brass up to 150°C 1.4571 up to 200°C
Connection material	CuZn - alloy						Stainless steel
Thread	G 1/8 B without male				G 1/4 B		Others on request
Connection position	radial bottom	centric back	radial bottom	centric back	radial bottom	centric back	
Window	Glass						Plexiglass, clipped-on
Movement	CuZn-alloy						
Dial	Aluminium white, scale and letters black						Special scale
Pointer	Aluminium black						
Temperatures	Medium: Tmax 60°C, ambient: -40°C; Tmax 60°C						Hard solder up to 150°C stainless steel up to 200°C (medium-temp.)
Orifice							Ø 0,4; Ø 0,8
Weight approx. (kg)	0,07	0,065	0,075	0,071	0,15	0,15	

Type 4101, 4151, 4201, 4251, 4301, 4351

Dimensional drawing

Dimensions in mm



DRUCK & TEMPERATUR

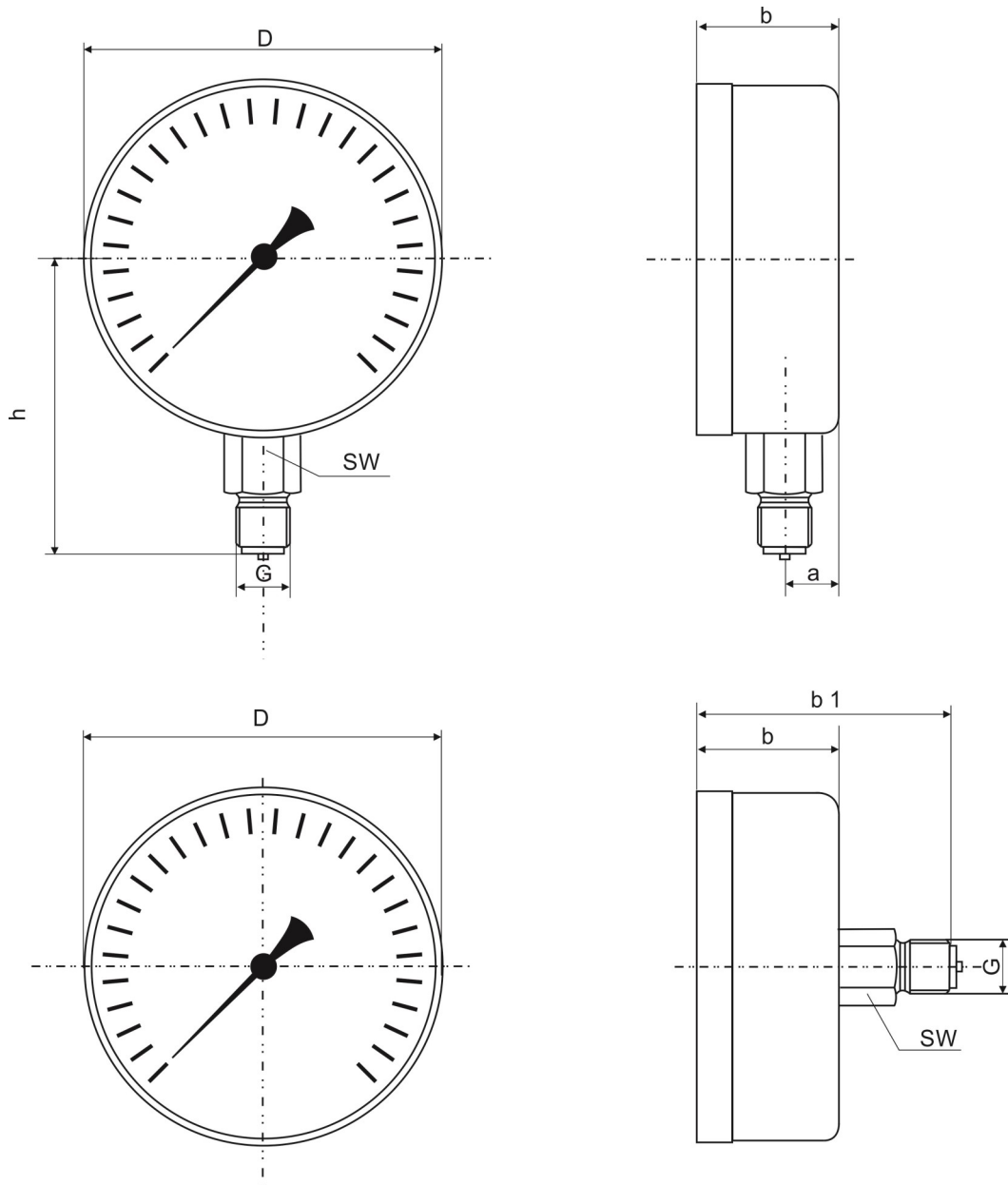

Type	NS	D	G	a	b	b1	h	SW
4101	40	42	G 1/8 B	8	24,1		39	14
4101	40	42	G 1/4 B	8	24,1		40,5	14
4151	40	42	G 1/8 B		26	39		14
4151	40	42	G 1/4 B		26	47		14
4201	50	53	G 1/4 B	9	26		47	14
4251	50	53	G 1/4 B		24	42		14
4301	63	62	G 1/4 B	10	28,3		53,5	14
4351	63	62	G 1/4 B		30	52		14