

BRASS WAFER SPRING CHECK VALVE PN16



Size : DN 32 to DN50
Ends : Between flanges ISO PN10, PN16, PN25, PN40
Min Temperature : - 10°C
Max Temperature : + 250°C
Max Pressure : 16 Bars
Specifications : Spring type
All positions
Metal / metal tightness

Materials : Brass body

BRASS WAFER SPRING CHECK VALVE PN16
SPECIFICATIONS :

- Spring type
- All positions (respect the flow direction indicated by the arrow)
- Metal / metal tightness
- Stainless steel disc

USE :

- Heating, watering and water distribution
- Min Temperature Ts : - 10°C
- Max Temperature Ts :+ 250°C
- Max Pressure Ps : 16 bars (see graph under)

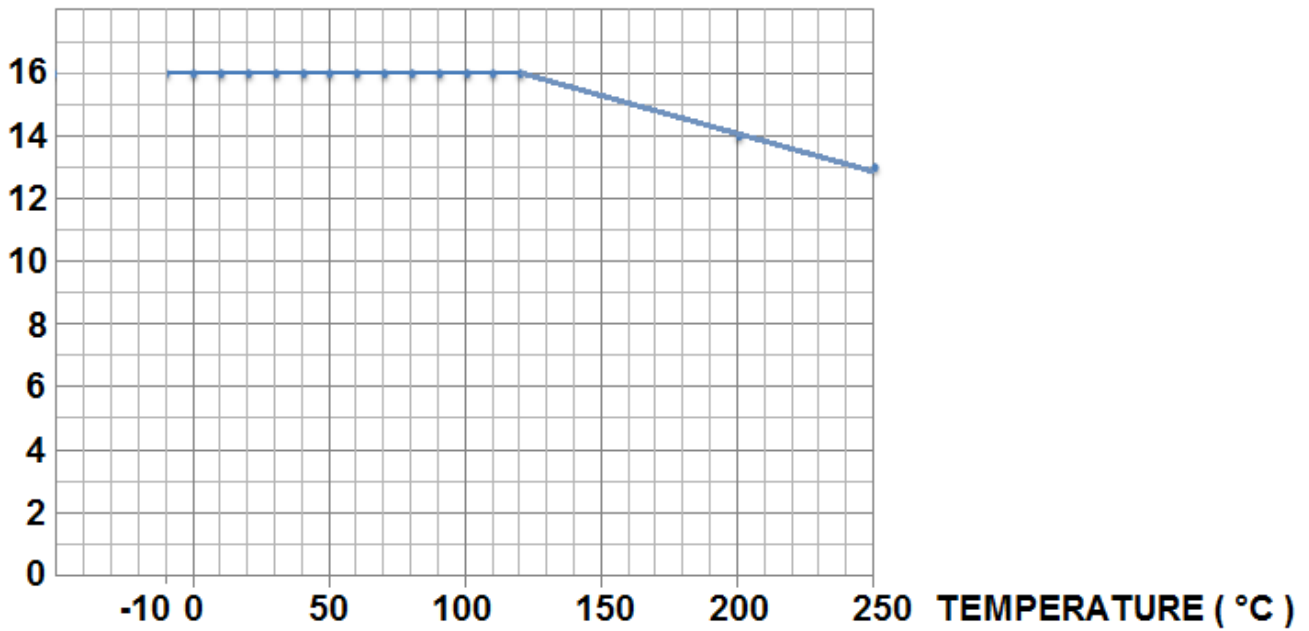
PRESSURE / TEMPERATURE GRAPH (STEAM EXCLUDED) :
PRESSURE (Bar)

FLOW COEFFICIENT Kvs (M3 / h) :

DN	32	40	50
Kvs (m3/h)	16	26	40

RANGE :

- Between flanges ISO PN10, PN16, PN25 and ISO PN40 **Ref. 385** from DN32 to DN50

BRASS WAFER SPRING CHECK VALVE PN16

HEAD LOSS GRAPH:

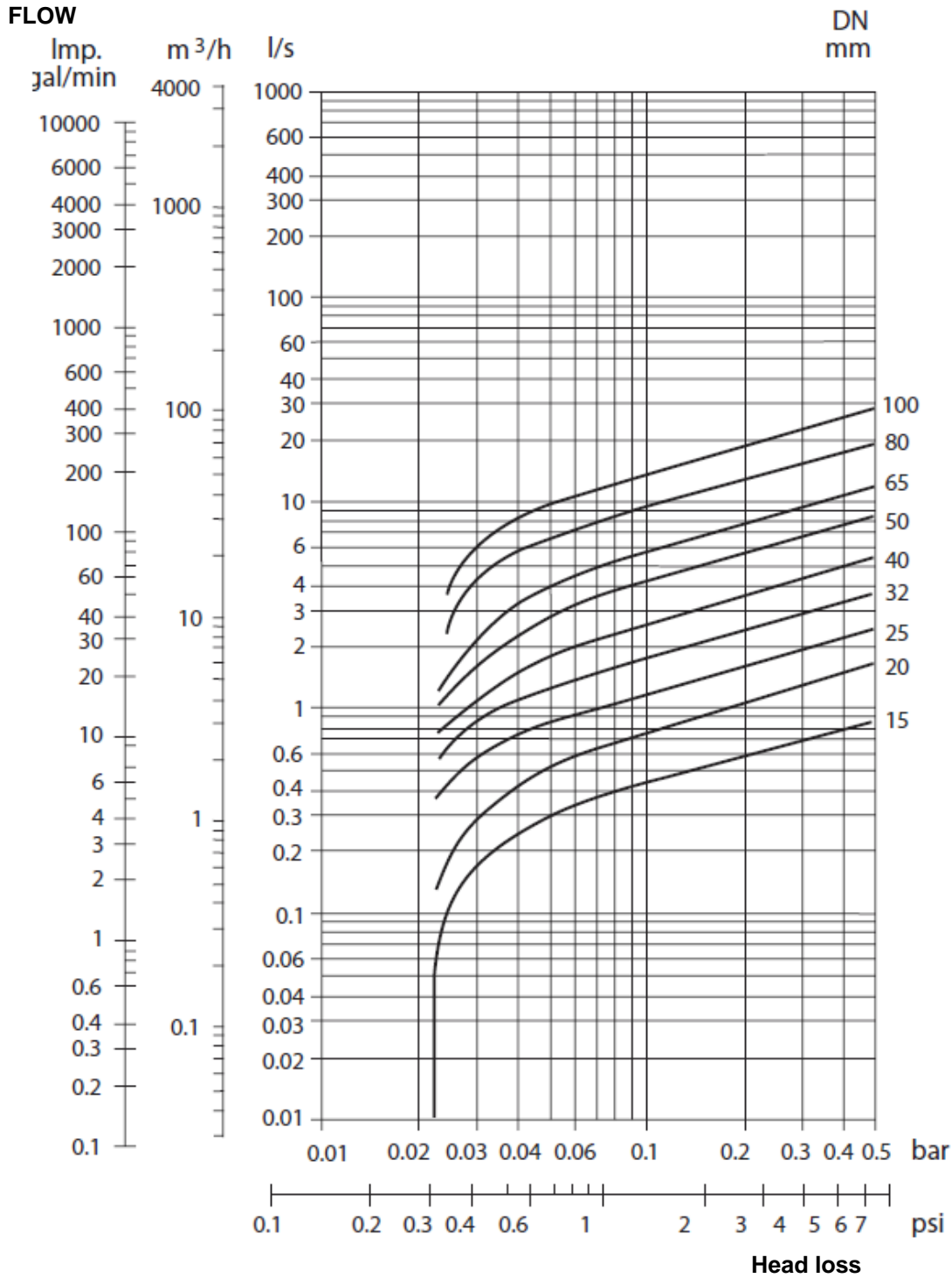

BRASS WAFER SPRING CHECK VALVE PN16

OPENING PRESSURE (in mbar) :

DN	Vertical Position Ascending fluid	Horizontal Position
DN 32	27 ↑	20 →
DN 40	28 ↑	20 →
DN 50	29 ↑	20 →

MATERIALS :

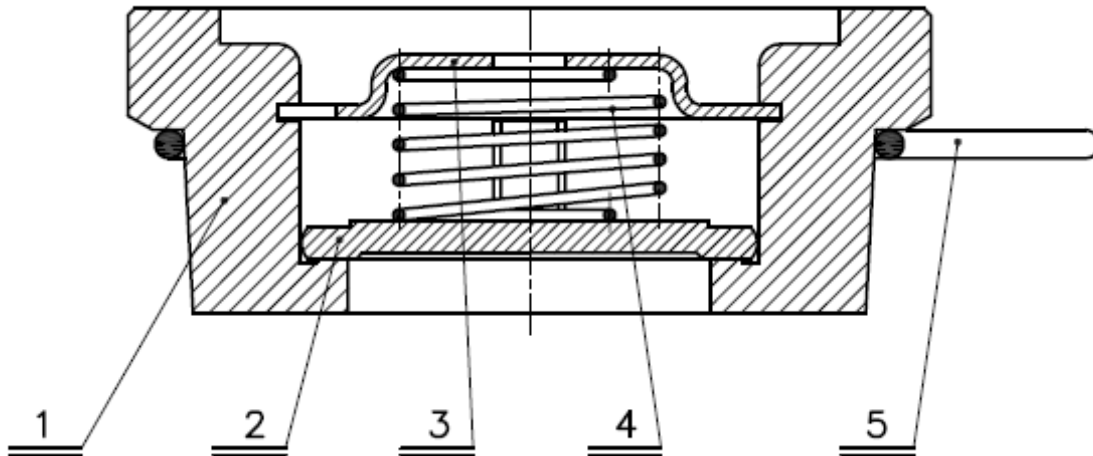

Item	Designation	Materials
1	Body	Brass CW 617 N according to EN 12165
2	Disc	SS 316
3	Spring holder	SS 316
4	Spring	SS 302
5	Centering hoop	SS 302

BRASS WAFER SPRING CHECK VALVE PN16

SIZE (in mm) :

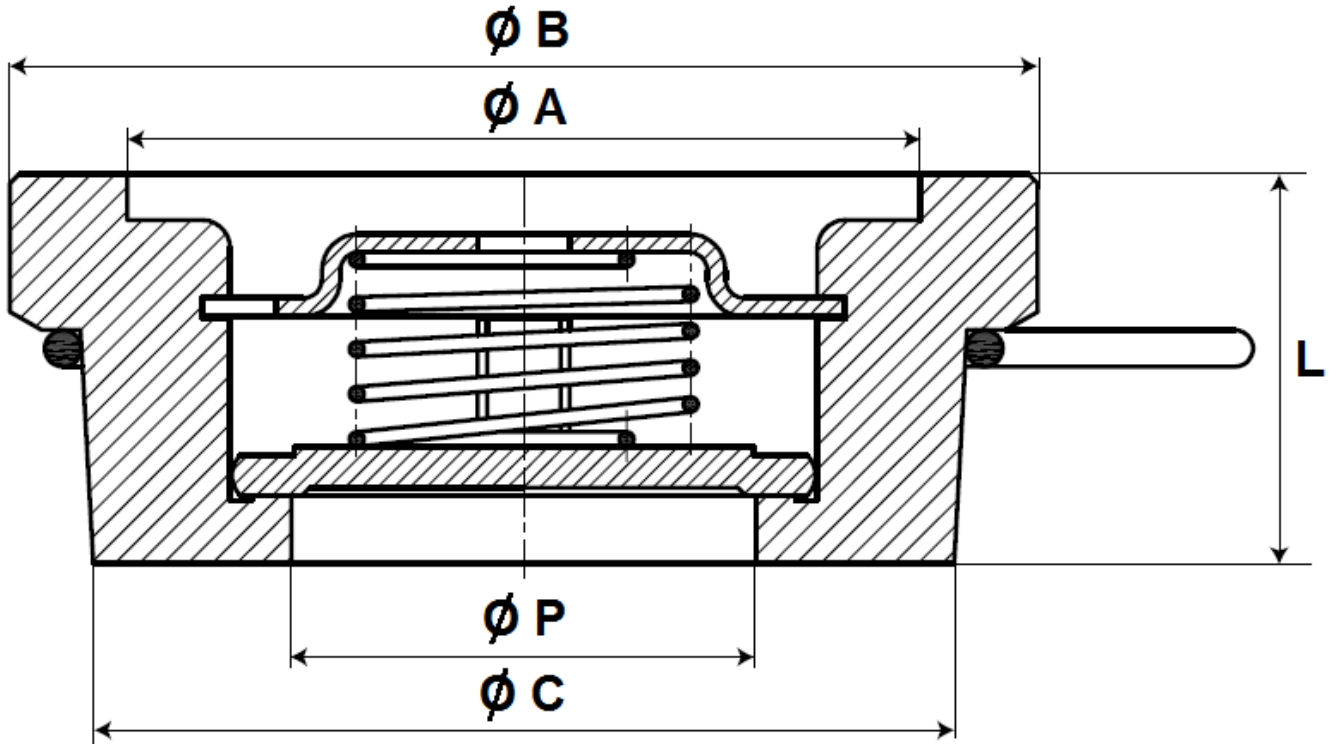

Ref.	DN	32	40	50
385	Ø A	52.4	63.1	75.4
	Ø B	72	82	95
	Ø C	62	74.5	87.5
	Ø P	31.7	39.3	48
	L	28	31.5	40
	Weight (Kg)	0.360	0.550	0.950

BRASS WAFER SPRING CHECK VALVE PN16

STANDARDS :

- Fabrication according to ISO 9001 : 2008
- DIRECTIVE 97/23/CE : CE
Risk category I module A
- Designing according to EN 12334
- Tests according to EN 12266-1, range A
- Length according to EN 558 series 49

ADVICE : Our opinion and our advice are not guaranteed and SFERACO shall not be liable for the consequences of damages.
The customer must check the right choice of the products with the real service conditions.

BRASS WAFER SPRING CHECK VALVE PN16**INSTALLATION INSTRUCTIONS****GENERAL GUIDELINES :**

- Ensure that the check valves to be used are appropriate for the conditions of the installation (type of fluid, pressure and temperature).
- Be sure to have enough valves to be able to isolate the sections of piping as well as the appropriate equipment for maintenance and repair.
- Ensure that the valves to be installed are of correct strength to be able to support the capacity of their usage.

INSTALLATION INSTRUCTIONS :

- **Before installing the check valves, clean and remove any objects from the pipes** (in particular bits of sealing and metal) which could obstruct and block the valves.
- **Ensure that both connecting pipes either side of the check valve (upstream and downstream) are aligned (if they're not, the valves may not work correctly).**
- **Make sure that the two sections of the pipe (upstream and downstream) match, the check valve unit will not absorb any gaps. Any distortions in the pipes may affect the tightness of the connection, the working of the check valve and can even cause a rupture.** To be sure, place the kit in position to ensure the assembling will work.
- Make sure there is enough space so that the disc can be opened totally in the pipe.
- If there is a direction changing or if there's another material, it's better to take away the check valve so that it is outside the turbulence area (**between 3 and 5 times the ND before and after**).
- After a pump please refer to norm NF CR 13932 to install the check valve.